

INDEX

SECTION ONE

(PAGE 2 - 3)

GENERAL RULES APPLICABLE TO ALL CLASSES

SECTION TWO & THREE

(PAGES 4 - 15)

JUNIOR, PROD A, HOT ROD RULES

SECTION FOUR

(PAGE 16)

MEETING PROCEDURE

SECTION FIVE

(PAGE 17)

CONDUCT OF MEETING

SECTION SIX

(PAGE 18)

1450 PROD ROD / SALOON ROD RULES

SECTION SEVEN

(PAGE 22 - 26)

CONTACT CLASSES – BANGERS / F2 STOX / STREET BANGERS

SEGTO TRACKS

PAGE 27

Age for Junior Racing is 10 – 17

Minimum age for racing in Adult classes is 17yrs except:

Juniors with racing experience may be considered to race in Adult classes before they are 17.

Any Junior wishing to race in an Adult class before they are 17 must gain the promotions approval.

These regulations have been written and compiled with the spirit of fair motorsport and competition in mind. Competitors are therefore expected to be responsible for the preparation of their cars and compete at any meetings attended in the same spirit with which they were written.

It is impossible to guarantee racers safety, dangerous & fatal accidents can and have happened, all racers compete at their own risk with no comeback whatsoever on the organisers / Landowner. It is recommended that racers take out Personnel Accident Insurance to cover them against injury whilst racing.

SECTION ONE

GENERAL RULES APPLICABLE TO ALL CLASSES

1. All racecars to be prepared according to the rules specified for each class in this Rule Book.
2. Drivers must wear crash helmet with visor or goggles. Helmets must be of BS 6658, Snell 70, 80 & 90 EC 22.05 P/J 0511884 standard, without chin pad, in sound condition. Drivers to wear fireproof overalls and gloves at all times when racing.
3. A 5mph speed limit is imposed in spectator and pit areas. Racecars may not be 'tried out' in the pits. Contravention will result in suspension. No racecars in the spectator enclosure.
4. Drivers must not consume Alcohol during a meeting and may be banned. Anyone under the influence of Alcohol or Drugs will not be allowed to race.
5. All rubbish & litter to be placed in the bins or taken home. **No Wheels or Tyres or Batteries** to be left at the track. Any offenders will be suspended or banned from racing.
6. If your car stops during a race you leave it at your own risk. You are safer helmeted and harnessed in your car. If you are seen to be in danger, or injured, the race will be stopped.
7. All racers must present a suitable fire extinguisher at scrutineering.
8. All cars to have full silencer system.
9. All cars to have an efficient highback seat and head restrainer.
10. If bonnet, boot or doors come open / fall off - automatic black flag.
11. Cars with punctured tyres must stop racing or be black flagged.
12. **Dangerous or malicious** driving by Teams or Individuals will result in suspension.
13. Physical violence between racers, mechanics or spectators will not be tolerated and may result in suspension. Racers may face punishment for the actions of their mechanics / supporters / Parents.
14. Physical violence to any person helping to run the meetings will mean automatic suspension.
15. Race Controller's and Clerk of the Course decisions are FINAL.
16. Standing lights start for ALL classes. Starting procedures:-
RED - Prepare.
GREEN - Go.

RED - Race stopped or end of race.
Jumping the start - procedure will be repeated with offender going to back of the grid.

17. FLAGS:

GREEN - Prepare for start light procedure.
YELLOW - Obstruction on track, drive with caution.
BLACK - You are disqualified, pull into the centre.
RED - Race is stopped or stop racing at the end of the race
WHITE WITH BLACK X - Warning, you will be docked one place.
BLUE - Non Contact, hold your line or make way for overtaking cars
CHEQUERED - End of race, keep racing until red flags and lights are shown.

18. In all classes Black and Black Cross flags are recorded with Championship points deducted at the end of the season. Black flag = 5 points deducted. 5 x Cross flag = 5 points deducted.

19. Number of Laps/Points - Number of laps is determined by the number of racers and will be shown at start of each race. Points in non contact classes are awarded for each race descend from 10 points down to 1 point. 1st . 10 2nd . 9 3rd . 8 4th . 7 5th . 6 6th . 5 7th . 4 8th . 3 9th . 2 10th . 1.

Points for Bangers and Street Bangers are awarded for each race 1st . 6 2nd . 5 3rd . 4 4th . 3 5th . 2 6th . 1 Two attendance points per meeting will be awarded to each competitor that competes. Overall club champion will be the driver who accumulates the highest number of points over the whole season, and has received minimal disciplinary action.

20. All racing at Standlake is graded. Racers must paint their roof according to whichever grade they have attained. Racers grades may be amended at any time including during a meeting. All cars to have clear roof numbers with black on white numbers, Bangers 2ft x 1½ ft. Race number also to be shown on doors.

21. Racing can be dangerous & accidents do happen, all racers compete at their own risk with no comeback whatsoever on the organisers / Landowner. It is recommended that racers take out Personnel Accident Insurance to cover them against injury whilst racing.

22. The scrutineers and promotions decisions are final.

SECTION TWO - JUNIOR, PROD A, HOT ROD RULES

**UNLESS IT STATES YOU CAN DO IT,
YOU MUST ASSUME THAT YOU CANNOT**

JUNIOR RULES

1000cc Mini Saloons only.	No fuel injection
2 Wheel drive only.	Dash bar
Window net (not metallic)	Crotch strap
Double door bars off side (Drivers side)	Minimum 14" steering wheel
Single door bar near side (passenger)	Padded steering column
Drivers must wear a neck brace	"J" on roof
No locked differential	

No Juniors allowed to race until their 10th birthday and then they must be able satisfy the promotion as to their capabilities to handle their car under race conditions.

Birth certificate / Passport or proof of age is required when first registering to race at Standlake.

Upper age cut off date is August 31st.

1. If your 17th birthday is before August 31st you may:
Race in the seniors for the whole season.
Race in the Juniors but change to the seniors immediately you are 17 years old.
2. If your 17th birthday is after August 31st you may:
Race the whole season in the Juniors.
Change to the seniors when you are 17.

Proven racers may start in the seniors earlier, with the promoters consent. Supervised practice and parent coaching will be available on race days.

1. All car preparation / engine build as per Prod A except: Mini Saloons only (No estates or pickups).
2. All junior racing is **NON CONTACT**.
3. No car sharing, one car only to be used at any meeting.
4. To start with cars should have two front seats and harness until the promotion is satisfied that the junior is safe and able to race by her or himself.

5. Great care must be taken driving through the pits. A 5mph speed limit is imposed in the pits. No passengers other than Parent / Guardian. Contravention may result in suspension.
6. All safety wear to be worn until off of the circuit.
7. Roll cages: as Prod A rules. Roll cages that are cut for removing or refitting must have a sleeve welded all the way round the outside, sleeve must be at least 2 inches either side of joint. Welds must only be covered with paint (**NO MASTIC**).
8. Junior racers to be graded as other classes.
9. Intimidation bullying or general misbehaviour by **JUNIOR RACERS, PARENTS, GUARDIANS OR OTHERS WILL NOT** be tolerated and may result in suspension.
10. These rules are primarily for drivers safety, it is however impossible to guarantee drivers safety and all racers should realise they race at their own risk. It is recommended that all racers take out their own Personal Accident Insurance to cover them against injury whilst racing.
11. As with other classes, Race Controller's and clerk of the course decisions are **FINAL**.
Junior and parent or guardian to have read and understood race rules issued to all racers.

For full preparation of cars see section three

PROD A RULES

Up to 1000cc FWD and 1100cc RWD.

Push rod or OHC. engines as homologation list.

Due to valve springs for 1000cc OHV Vauxhall being unavailable from Manufacturers or Factors, the following alterations are permitted: 1400cc 8 valve OHC valve springs are permitted with the addition of either one solid spacer under exhaust valve spring or original turntable ground off, or the centre of 1400cc turntable machined to fit valve guide. The solid spacer used must not measure any more than 7mm. Part numbers for 1400cc components, Spring 90265608 G.M. Spring VSP 954255 (Factor), Turntable 90106266. Washer 90128720.

Single point injection is permitted, standard original equipment only.

2 Wheel drive only, single engine only.

Anti Roll bars are not permitted on Novas.

Cars must be of a model originally fitted with 1 only single choke carburettor, max 2 valves per cylinder, with engines of up to 1000cc front wheel drive or 1100cc-rear wheel drive. No Cooper S, GT., Rallies, Sports, Special Editions, or engine parts permitted etc:

No modifications to engines permitted except as listed.

Production drivers please note: -all cars must be as were produced by the manufacturers, except for permitted modifications.

If a driver refuses to allow SEGTO to fit an ECU they will be deemed illegal. ECU must remain standard with standard manufacturer's factory settings, with no additions, and must remain standard to engine fitted. If a car is suspected, it will be checked and /or be taken to a rolling road at driver's expense. If not stated that it can be done then it cannot be done.

1. 60 thou (0.060") maximum overbore permitted and any other renewal or replacement of worn components.
2. **No reprofiled or remanufactured camshafts**, manufacturers original or manufacturers replacement 1/2" wide lobe, 3/8" lobe cam is allowed but must be within the manufacturers tolerances. Camshaft Nos 6267 or 4717 are permitted. 4717 can be identified by 1 ring between lobes of cylinder no 3, 6267 can be identified by 1 or 2 ring between lobes of cylinder no 2. Other vehicle camshafts will be checked against manufacturer's Technical Data.
3. Manufacturers dowel or woodruff keys must be fitted as standard.
4. Engine balancing is permitted, No machining of pistons except for balancing purposes and this can only be carried out on the inside surface of pistons, and they must not protrude above block face, but some manufacturers have pistons that protrude as standard, so particular vehicles will be checked on their merit, according to manufacturers tolerances, for that specific vehicle. One piston and one con rod must remain as standard. Competition pistons are not permitted.
5. No centre main crankshaft straps.
6. When closed the valve head must protrude into the combustion chamber and not be recessed.
7. Valve springs must remain standard to the engine used.
8. No matching or machining of carb to inlet or manifold to block. Inlet and exhaust manifold must remain as standard.
9. Head numbers 12A 1456 2A 629 Minis or "A Plus" CAM 4810. Cylinder heads may be skimmed, but no modification to oilways. Lead free inserts & 3 angled valve seats may be used.
10. Oil pump pick-ups may be relocated, sumps may be baffled.
11. BL "A+" 1000cc engines or running gear are permitted. Crank, rods & pistons must remain as standard to block.
12. No "S" type distributors on BL."A" series and A+ engines. Distributor must remain as standard to the engine used, and fitted with a vacuum capable of working..
13. Electronic ignition permitted if fitted as standard. A+1000cc camshafts, heads and springs may be interchanged with A series 1000cc or vice versa.

14. Fitting of dynamo/alternator optional.
15. No duplex timing chains.
16. Air filters free. No ram pipes, air scoops, turbo nor any other forced induction.
17. Carburettor butterfly must not be modified or removed.
18. All cars must retain original carburation. 1½" maximum. S.U. Needles must remain round.
19. No twin specialist carburettors
20. Casting and or forging marks must remain
21. If not stated that it can be done then it cannot be done.

Transmission

All gearbox must retain all gears. Nova must retain 1.96 second gear Gearboxes and axles must be as originally fitted to the car with NO modifications except:- Differential final drive ratio may be altered within the manufacturers range.

No competition or limited slip diffs permitted.

Differential may be locked completely by welding. (Not on Junior cars)

Out put drives & drive shafts must be within the manufacturers range.

Homologation list.

Citroen: AX, & Saxo. Fiat: 127, Panda, Uno, Ciquecento, & Seicento. Ford: Fiesta. Lancia: Y10. Nissan: Cherry, Micra. Vauxhall: Corsa, Nova. Peugeot: 104, 106, 205, 206. Renault: R5. Rover: Mini, Metro. Seat: Ibiza, Arosa. Skoda: Fabia. Suzuki: Swift upto 89. Talbot: Simca, Imp. Toyota: Starlet. Any car not on list please check before building.

For full preparation of cars see section three

HOT ROD RULES

Any modified saloon of unlimited size and any drive configuration.

Any car or manufactured pickup fitted with any make or type of engine in any position with drive configuration. Engine modifications free.

RWD rear engine - the rear bulk head can finish at the bottom of the rear side window aperture with a shield off at 45deg to shield the drivers back. All chains on chain driven cars must have adequate protection from drivers and other competitors.

Oil coolers must not be in window aperture.

Transmissions, axles and suspensions free.

Space frames are permitted (see Section 3 of Rulebook Rule 9).

No 4 wheel drives, Wheel width must not exceed 10J.

GRP bodied S/Saloon fitted with space frames must have steel plate welded to roll cage under roof.

For full preparation of cars see section three

SECTION THREE**RULES APPLICABLE TO JUNIORS, PROD A, HOT RODS**

1. **Presentation of cars.** All vehicles used, i.e. saloons, hatchbacks, pickups must retain the manufacturer's original silhouette, i.e. no cut downs. If a hatchback is used it must be fitted with original tailgate. Vehicles must be presented in a clean and tidy condition. All body panels, doors, bonnets and wings must be securely attached. Doors bonnet and boot must be securely retained with quick release fixings. Bungee straps and rubber hooks alone are not adequate. If any of the above become detached during racing this may incur a penalty. Boot floor must remain as standard if spare wheel well is excessively corroded it may be removed but must be replaced with material no more than original thickness in flat steel. No saloons shall be fitted with dumb irons or structural steel fenders, such as angle irons, joists, tubes or other circular or rectangle section at the front, rear, and sides of cars. Original steel bumpers to be removed. Integral plastic bumpers are permitted. Radiator or any other cooling system pipes that run through the driver's compartment must be of metal and completely shielded from the driver. Ballast in any form is not permitted. (Juniors, Prod A distributors must be fitted with vacuum capable of working). No distributor protection allowed. Electronic traction control not permitted. Isolator switch must be in the rear drivers side triangle on the roll cage. Towing eyes front and rear are recommended.
2. **Body Shells & Suspension - Juniors - Prod A**

The body shell and sub frame of all cars must be of steel as standard. Bonnets, boots & doors may be skinned. Doors must be able to be opened from the inside and outside. Drivers must be able to open door from inside while sitting in the seat. Apart from one-piece fronts on BL Minis which must be detachable as a whole and be clipped with bonnet pins or clips, not bolted. Cars with detachable one piece front, steel or otherwise will be allowed 2 lengths of 1" (25mm) x 1" (25mm) box or round tube of no more than 10swg bolted at both ends diagonally from flitch panel to subframe, (see figure 1).

Flip fronts, one piece detachable fronts (where inner flitches have been removed) can be fitted with 2 x 13mm headed bolts on inside/A panel, and plate same size as body work, 2 pins or clips on top. Grilles must not be replaced with checker plate. No welded grille. All internal

structural bodywork must be retained, no drilling of structural panels i.e:- door posts, floor, inner wings, bulkheads and tailgate.



Inner flitches forward of front suspension point may be removed no strengthening allowed, and must not be braced. A bar to support grille may be used no more than 18 gauge maximum, and must be $\frac{1}{4}$ " section (2+) 5cm x (1+) 2.5cm, inner wing must not be cut within the suspension. All saloons must retain their original or soundly constructed substitute rear parcel shelf. Shock absorbers may be uprated and the mountings relocated. Coil over shock absorbers are not permitted, unless fitted as standard. No other suspension modifications, apart from camber/caster, KPI improvements allowed. Standard items may be lowered. Quick steering racks are not permitted. No aerofoils, spoilers or air scoops, if arches and sills are fitted, they must not exceed 2+ (50mm) wide at their uppermost point of fixing. All sharp edges must be made smooth. If the original front panels are not available (i.e. Starlets), a replacement flat panel of not more than 18g. Mild steel may be used, & must be straight & flat but must not exceed past the front edge of the front wing. Nova fronts to be standard as fitted from factory with bumper if required. It is prohibited to reinforce the front apron/panel. Suspension must not be adjustable.

Hot Rods - Any fibreglass must not exceed $\frac{1}{4}$ " (6mm) thick. GRP bodied Hot Rods fitted with space frames must have steel plate welded to roll cage under roof. Kevlar doors are permitted. Skirts or extension sills are permitted but must not exceed the original panel part thickness if constructed of steel. All sharp edges must be made smooth. No double skinning of body panels allowed. Any patching of exterior panels must not exceed the thickness of original panel part.

All drivers compartments must remain metal and sealed from the track. Both front doors must open with easily accessible fixings. Cut down doors are not permitted. Doors must open on hinges or be detachable. Fibreglass or Kevlar panels may be used to substitute any exterior panels. Any non-original engine/body configuration must be fitted with a 10 gauge scatter shield bolted to bellhousing between the engine and driver. Towing eyes front and rear are recommended.

3. **Engine Sealing.** It will be the drivers responsibility to ensure that the following bolts are drilled to enable the engine to be sealed should the need arise.

Junior, Prod A:

1 Head Bolt	1 Block to Bellhousing Bolt.
1 Sump to Block Bolt.	1 Timing Cover Bolt.
1 Inlet Manifold Bolt.	1 Rocker Box head Bolt
1 Carb to Manifold Bolt.	1 Diff Bolt

4. **Sharp Edges.** All sharp edges must be smoothed off. All cars must be of sound construction and condition, and must have a positive fastening on all doors and body parts:- there must be no dangerous sharp edges to bodywork. All cars that roll will be subject to Re-Scrutineering
5. **Fireproof Bulkheads.** All cars must have protective bulkheads of non-flammable material between the engine and driver, and between the fuel tank and driver, capable of preventing the passage of fluid, flame or steam, etc. All gaps must be sealed with flame retardant material.
6. **Fire Extinguishers.** Fire extinguishers in race car is optional, but all drivers must have one with their race number stamped/painted on it and it must be taken to scrutineering. If fixed in the car drivers must familiarise themselves with the method of operation of their respective extinguishers. Fire extinguishers must be a minimum of .9 kilo. size.
7. **Fuel Lines and Tanks.** Petrol from Service Stations pumps only. Fuel additives permitted. Fuel lines must run inside the car, and be of metal. Where fuel line passes through the bulkhead or panel it must be protected by properly fitted grommets in rubber or other suitable material to prevent chafing. Proprietary fuel taps are permitted. There must be no rubber joints in the drivers compartment. Tanks must be

of a maximum 2-gallon capacity and fitted with a breather vent open below the bottom level of the tank which continues through the floor to prevent spillage if inverted. Tanks must have positive sealing caps. Original fuel tanks must be removed. The tank must be isolated from the driver behind a fireproof bulkhead or in a fireproof box, at the furthest practicable point from the driver and engine compartment in the rear of car, within the confines of the roll cage, and securely fitted. Scrutineers to advise driver of opened engine race cars they must have adequate protection from fuel tanks, not only for driver also other competitors. Any oil pipe that runs through the drivers compartment must be steel braided.

8. **Nitrous Oxide.** No injection of Nitrous Oxide or any forced induction of gas of this type is permitted in any class.
9. **Roll Bars / Cages.** All non contact groups must have a soundly constructed full roll cage (see diagram figures 2a & 2b.) fixed to the body or chassis, welded to footplate minimum size 4" x 4" (or 100mm x 100mm) bolted or welded to car. The surrounding floor area must be sound. Minimum requirements for all cages are 1¼" (30mm) tube or 1¼" box section (30mm x 30mm) of not less than 12swg. (2.5mm). Two bracing struts must be fitted to the rear hoop. A centre bar from the front to rear between the main hoops must be fitted, or this may be diagonal form corner to corner. A diagonal bracing strut must be fitted from the drivers head to lower fixing of rear bar.(see figure 2b) All joints must be welded or bolted if on an approved manufacturers roll cage. If full width hoops are cut and welded there must be additional webs welded or bolted minimum size 2" x 2" x 10 gauge (50mm x 50mm). All welded in roll cages must have webs on all welded roof joints, a total of nine webs in roof joints, or tubes may be fitted to triangulate right angles. All bolt together roll cages must have a minimum of two (2) bolts per joint if not they must have webs. A 'chicken bar' must be fitted at hip height on drivers side in the door aperture, (Specials on both sides) minimum tube size as for roll cages, welded or bolted between front and rear uprights of roll cage. Chassis/roll cage must stop 6+ short of front & rear panel. Alloy cages are not permitted.

Space Frames for Hot Rods: All body shells must retain original silhouette with complete steel roof. The construction of space frame vehicles must have roll cage or drivers cell constructed of round or square section tube. Any construction other than engine/gearbox and suspension supports forward of front suspension & behind rear

suspension must not be of a type that can be classed as ironing up. Any heavy metal i.e. Chassis/roll cage must stop 6+ short of front & rear panel.

Minimum Roll cage tube sizes:

Round 30mm or 1¼" dia.

Square 30mm x 30mm or 1¼" x 1¼"

Minimum thickness of 2.64mm or 12swg.

Alloy Cages are not permitted.

The scrutineer's decision is final.

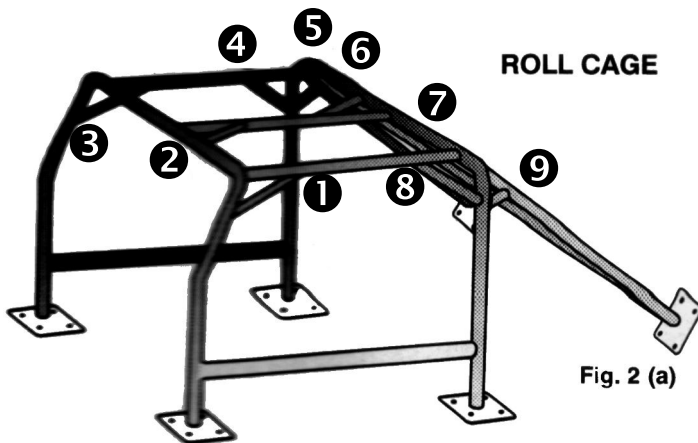

Fig. 2 (a)

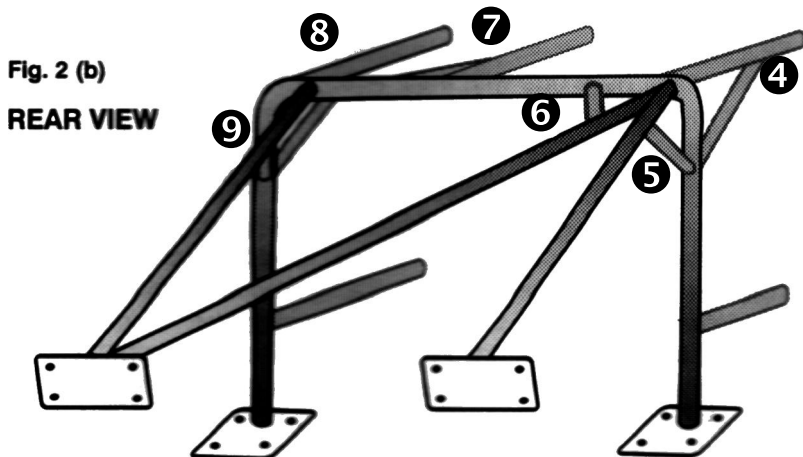

Fig. 2 (b)

REAR VIEW

10. **Batteries.** All must be covered with a non-metallic material and securely fixed so they do not become dislodged in the event of an accident of any kind. If fitted inside the car driving compartment, they must be securely fitted within a box and leak proofed, if fitted in the boot the battery must be segregated from the fuel tank and covered in non-metallic material. Maximum two batteries to be fitted, and these of reasonable size 2 x 6volt or 2 x 12volt.
11. **Master switch/ignition switch on all groups.** Key type ignition switches must not be used. Only lever operated or push/pull switches will be accepted, and must be marked "ON" and "OFF". Steering lock mechanisms must be removed. Isolator switch must be in the rear drivers side triangle on the roll cage and must be capable of isolating battery and cutting engine. And must be marked On/Off.
12. **Brake Lights.** All cars must be equipped with two rear lights of the anti-crash type, i.e. fog lights, fitted one each side of rear of car. Multi LED units are permitted. On saloons inside rear window aperture. These must be operated by depression of the car foot brake pedal only.
13. **Starter Motor.** Starter motors must be fitted and be capable of starting the engine at all times.
14. **Wheel Spacers:** are not permitted in Juniors or Prod A groups, (Hot Rods fitted with wheel spacers must not exceed exceeding 1" (25mm) thickness. Multiple or laminated spacers prohibited.
15. **Wheels Tyres and Brakes.** - Brake pipes must run through the drivers compartment. Efficient brakes must be on all wheels at all times, Hand brake is optional. Cars must not have more than four wheels, All nuts securing wheels to be of steel and in thread contact over a minimum length of 1 ½ times bolt/stud diameter. Safety wheel nuts to prevent wheels pulling off over standard nut are recommended. Tubed tyres are recommended. All cars must retain same diameter wheels on same axle. Sidewall gaiters are not permitted. Scrutineers should advise drivers that the tyres they intend to use are legal, for the group they are racing in, as some tyres marked road legal could be deemed illegal, and not within the spirit of the rules.

Juniors, Prod A. Brakes are free within the manufacturers model range. Adjustable bias brakes valves are not permitted. All groups can use alloy wheels provided correct wheel nuts and studs/bolts are

used. Wheel diameters are free but must not exceed 6+J width. Wheel spacers must not be used unless fitted as standard equipment for the cars concerned. Any disc 7 or 7 ½ %single pot calipers only. No vented discs, unless fitted as standard. No modification to rear brakes. Road legal tyres only permitted and maximum tyre size must not exceed 560 or 165. Yokohama\$ only AO32R are permitted. Colway max sport intermediates are not allowed.

Hot Rods - Efficient brakes must be on all wheels at all times. Brakes are free within manufacturers range. Wheel width must not exceed 10J. Outside edges of tyres must remain within the confines of the bodywork. Tubed tyres are recommended. No more than two wheels to be fitted to one axle. All cars must retain same diameter wheels on same axle. No stud or chained tyres permitted. Sidewall gaiters are not permitted. Efficient brakes must be on all wheels at all times. Brake pipes must run through the drivers compartment.

16. **Exhaust Systems.** All vehicles must have efficient exhaust system. A decibel reading of 98 decibels measured on the track under racing conditions will be enforced. The exhaust system must be isolated from the driver i.e. beneath the floor or if run inside the car, secured (for protection purposes) in casings of sound material. Inadequate / faulty systems or losing part of the exhaust while competing may result in disqualification.
17. **Racing Numbers.** Racing numbers will be allocated when enrolling with a club. Numbers must be displayed on both sides of the vehicle and may be of a contrasting colour, and as large as possible, minimum 10 inches high with a stroke width minimum of 1.5 inches. The club prefix X must also be displayed before the number, minimum of 4 inches high (102mm). All cars must have a roof fin fitted above the gutter line, not to the side of vehicle. The roof fin must be white and be big enough to carry a solid black club prefix before the number, minimum 4 inches high, with a stroke width minimum of half an inch, and solid black numbers, minimum 6+ (153mm) high and minimum stroke width 1+(25mm). It is the drivers responsibility to ensure their vehicles prefix and numbers can be clearly seen to enable them to be lap scored.
18. **Mirrors.** Vehicles must be fitted with adequate rear view mirror/s, glass is not recommended.
19. **Glass.** The only glass permitted is a laminated windscreen. Side windows and rear screen if fitted must be Lexan only. All windows

must be clear not tinted If fitted with windscreen wiper/washer, washer tank must not exceed 4 gallons capacity and must be fitted immediately behind the drivers seat. A non-metallic door net must be fitted on all vehicles excluding Specials.

20. **Safety Belts / Harness**. Seat belts are compulsory under practice / race conditions and must be of the full harness type (minimum five point fixing) and comply with F.I.A. regulations. Push button release must be forward facing, not side facing. Rear fixing must be at 45 degrees to seat back for non-race high back bucket seats. If seat belts are involved in a severe accident it is recommended that they should be discarded and replaced. Manufactured race seats with the correct slots for the harness to go through are allowed a maximum 45 degree angle point of fixing.
21. **Seats** - must remain in or as near to original position and must not tilt, hinge or fold. Seats must be bolted to a soundly constructed floor at four points. If runners are fitted to the seat, both sides must be bolted together. You may use original seat belt anchorage points if positioned appropriately providing the area is sound. When bolted through the floor, seat belt fixings must have a minimum size plate/washer of approx 3+x 3+x 1/8+(75 mm x 75 mm x 2.6 mm) under floor, through which seat belt fixing must pass. Fibreglass seats are not permitted but Kevlar seats are accepted. Head restraint incorporated in your seat is compulsory.
22. **Crash Helmets & Visors**. The wearing of crash helmets and seat belts is compulsory under practice/race conditions. Crash helmets must be class A (EC2205 or P/JO 511) standard and not fitted with a chin pad. In the interest of safety, Helmets that do not comply will be confiscated. Visors or goggles are compulsory and must be worn during practice and racing. They must be shatterproof, if any of the above is removed whilst under race conditions the driver may be disqualified.
23. **Clothing**. Drivers must wear full overalls during practice and racing. Clothing of fireproof material is compulsory. Nylon is not permitted. Gloves are compulsory in all classes when racing.
24. **Loose Equipment**. All loose equipment must be removed from inside the vehicle when presented at scrutineering.

SECTION FOUR - MEETING PROCEDURE

25. **Accidents.** In the event of an accident only the course marshals, club officials, Safety Officer and First Aid personnel will be permitted on to the circuit. Under No Circumstances whatsoever unless specifically directed by the Clerk of the Course, will Parents, co-drivers, mechanics or friends be allowed on the circuit.
26. **Tow trucks.** Tow trucks and breakdown vehicles will only enter the circuit at the direction of the Clerk of the Course. No matter what the circumstances, they must stay behind the safety barrier until authorised to proceed.
27. **Protests.** Protests against vehicle eligibility must be made in writing including vehicle race number and signed by the protesting competitor. This should be lodged no later than 30 minutes after the end of the final race with the clerk of course or stewards of the meeting accompanied by a £100 fee. The vehicle in question will be examined immediately or sealed to be examined within a period of 60 days. In the case of strip down at the end of season, driver and vehicle must be available for inspection at a venue to be decided. If the driver of the car fails to make the car available for strip down within these periods then the car will be deemed to be illegal. Failure by club officials to strip a car during the period given by the officials will mean that the car is deemed to be legal. Seals must not be broken, except by a person designated to examine the vehicle in question. It is the responsibility of the driver of the protested car, (if not in agreement with immediate examination) to deliver at his own expense such vehicle as is the subject of protest to a place determined by officials. If subsequent findings prove the protest to be unfounded the organisers shall have the authority, unless there are special reasons to the contrary, to order the competitor who lodged the protest to pay for reasonable costs of dismantling and reassembling, transportation and scrutineer's fees. If competitor shall refuse or otherwise fail to comply with any or all of the above regulations, judgment will be given by default and penalties awarded. The scrutineer's decision is final. A driver who is found to have an illegal car will be suspended at the discretion of the officials.
28. **Vehicle Eligibility.** Club officials/scrutineers reserve the right to strip or seal engine and/or components as deemed necessary on the day. No compensation fee will be paid. Competitors with illegal vehicles will be disqualified from the championship and all points forfeited.

29. **Rejection.** Club officials reserve the right at all times to reject any car which in their considered opinion represents an attempt to defeat the regulations, even though it may comply with the letter of the regulations.
30. **Grading.** A grading system for drivers is determined by points, Gold roof denotes class champion. Drivers are responsible for finding out their grade. Drivers will be graded after every meeting. A driver may be upgraded on the day in the fairness of the sport to other competing drivers. The officials reserve the right to re-grade any driver at an event. This will be decided by clerk of the course, drivers will be informed before the start of any race. Lining up - Grid sheets are posted for non contact classes, drivers are responsible for finding out their grid position.
31. **Roof Grades** must be shown. Whole roof painted or min (4+) 102mm strip on both sides (4+) 102mm above the gutter line.
32. **Number of Drivers per Car.** The number of the drivers per car at points meetings is one. Once a driver has raced in a particular meeting it is not possible for that driver to exchange, borrow/buy or lend a car with/from/to another competitor for use at said meeting. Any drivers found responsible for permitting a UN licensed and or UN indemnified person to enter the raceway in their vehicle will result in both parties receiving an immediate long term suspension.
33. **Indemnity Forms.** An indemnity form must be signed by the competing driver before the racing starts. Failure to conform will result in driver and all concerned being banned.

SECTION FIVE - CONDUCT OF MEETING

34. **Conditions.** It is mandatory that a competitor shall not take part in any competition organised by Standlake Arena unless he/she is in possession of a current competition license. Competitors under 18 years of age shall obtain a signature of Parent/Guardian. The indemnification must be signed using correct name, a Nom De Plume is not legal and will not be accepted. Officials and/or drivers must not consume drugs / alcohol during a meeting as they may be banned from that meeting.
35. **Arrival.** Trailers must be unloaded and parked where directed.

36. **Speed limit.** A speed limit of 5 mph. is imposed in all public sections of the field, the approaches to it and the paddock. This applies to all vehicles whether racing or not. Racecars may not be tried out, in the interest of safety anyone offending against this regulation will be summarily banned from the meeting and where applicable forfeit his/her entry fee. No warning will be given.
37. **Scrutineering and Signing On.** Upon arrival competitors should proceed to the pit area, unload competition vehicle and then proceed to remove all loose equipment. The competitor shall make certain the vehicle is ready for racing and proceed to the SCRUTINEERING area, taking with him/her their license rule book, crash helmet and visor as these will be inspected. Vehicles and equipment will be inspected for general safety and conformity with these regulations. Provided that the vehicle is considered satisfactory by the scrutineer, the driver will be handed back his signed license rule book which will be required when signing on to race. Competition cars shall be returned to pit area to wait for racing to commence. The driver will have to pay any outstanding fees before receiving permission to race.
38. **Practising.** No driver will be permitted to practice at any venue without explicit permission from the club officials concerned. Landowners must not be approached.
39. **Race Control.** is out of bounds to all during racing.
40. Anyone tampering with any track equipment or safety fences will be banned from Standlake Arena. Parents are responsible for their children's actions at all time while at the venue.
41. All persons attending this event are made aware that '**Motor Racing can be Dangerous**'

SECTION SIX

1450 PROD ROD RULES - Min age 17yrs

1. All racing to be strictly non-contact with severe punishment for offenders using banger tactics.
2. Drivers will be graded according to their ability and results.
3. Fast cars suitable for short circuit racing only.
4. Races to be of a duration according to car numbers.

Car eligibility and preparation rules

1. Maximum engine size 1450cc. Carburettor or Single point injection (no multi point injection)
2. Cars can be front or rear wheel drive. No 4 wheel drive. No Ford Cortina, Sierra or Capris. Check first with the scutineers if you are in any doubt about a cars eligibility.
3. All cars to be of standard manufacture with no engine transplants or carburation mods. Engines must remain absolutely standard to the car being used. **No** mixing & matching of engine parts within a manufacturers range.
4. No locked diffs or cambered wheels.
5. All cars to be of steel construction with sunshine roofs plated over.
6. All interiors, mouldings and lights, to be completely stripped. Laminated windscreens may be retained, all other glass to be removed. Original fuel tank to be removed and replaced with a tank (maximum 4 gallons) incorporating a vent pipe through the floor.
7. All racers must present a suitable fire extinguisher at scutineering, the extinguisher must remain accessible in the racers pit area for the duration of the days racing.
8. Original bumpers may be retained. Drawbars to be completely removed. Strictly no armouring anywhere on car.
9. All cars to have full silencer system, i.e. resonator box and silencer.
10. Cars to have 4 wheel brakes at all times. If brakes fail, cars to come off. All cars to have 2 brake lights in rear window.
11. Radiators to stay in original position, batteries to be secure and covered.
12. High backed seat including head restrainer to be solid and securely fastened.
13. Cars to be fitted with proprietary or approved 4 point min safety harness, securely bolted with large washers and plated to sound metal
14. Full rollcage to Section 3 spec recommended. Minimum requirement is an adequate H frame securely bolted to floor and roof to form a roll cage behind driver.
15. Drive shafts must remain standard to car used. Suspension may be lowered. Shock absorbers may be modified.

16. Steel or alloy wheels not to exceed 6J. Standard road tyres only. No racing or competition tyres. No Hoosier or R suffix Yokohama tyres.
17. All race cars must be painted and maintained in a tidy and presentable race condition. Roof grades to be painted accordingly (whole roof).
18. All cars to display race numbers clearly black on white or white on black on doors and roof fin.
19. All drivers must wear when racing, Fireproof overalls (Proban), gloves, Crash helmet which must have one of the following British Standard Numbers visible to the Scrutineer, BS 2495, 6658, Snell 70,80 & 90, EC22.05, P/J0511884 with visor and or goggles. Neck braces are also advisable. (Lace up neck braces must not be worn).
20. These rules are primarily for drivers safety, it is however impossible to guarantee drivers safety and all racers should realise they race at their own risk. It is recommended that all racers take out their own Personal Accident Insurance to cover them against injury whilst racing.

SALOON ROD RULES - Min age 17yrs

1. All racing to be strictly non-contact with severe punishment for offenders using banger tactics.
2. Drivers will be graded according to their ability and results.
3. Fast cars suitable for short circuit racing only. Preferably hot hatchbacks though Saloons or Estates are allowed.
4. Races to be of a duration according to car numbers.

Car eligibility and preparation rules

1. All cars to be absolutely of standard manufacture with no engine transplants or carburation mods. No limit on engine capacity, fuel injection allowed.
2. All cars to be front wheel drive. No 4 wheel drive.
3. No locked diffs or cambered wheels.
4. All cars to be of steel construction with sunshine roofs plated over.
5. All interiors, mouldings and lights, to be completely stripped. Laminated windscreens may be retained, all other glass to be removed. Original fuel tank to be removed and replaced with a tank (maximum 4 gallons) incorporating a vent pipe through the floor. Steering locks to be removed.

6. All racers must present a suitable fire extinguisher at scrutineering, the extinguisher must remain accessible in the racers pit area for the duration of the days racing.
7. Integral plastic bumpers permitted. Drawbars to be completely removed. Strictly no armouring anywhere on car.
8. All cars to have full silencer system, i.e. resonator box and silencer.
9. Cars to have 4 wheel brakes at all times. If brakes fail, cars to come off. All cars to have 2 brake lights in rear window.
10. Radiators to stay in original position, batteries to be secure and covered.
11. High backed seat including head restrainer to be solid and securely fastened.
12. Cars to be fitted with proprietary or approved 4 point min safety harness, securely bolted with large washers and plated to sound metal
13. Full rollcage to Section 3 spec recommended. Minimum requirement is an adequate H frame securely bolted to floor and roof to form a roll cage behind driver.
14. Drive shafts must remain standard to car used. Suspension may be lowered. Shock absorbers may be modified.
15. Steel or alloy wheels not to exceed 6J. Standard road tyres only. No racing or competition tyres. No Hoosier or R suffix Yokohama tyres.
16. All race cars must be painted and maintained in a tidy and presentable race condition. Roof grades to be painted accordingly, whole roof or min 4+strip down both sides of the roof
17. All cars to display race numbers clearly black on white or white on black on doors and roof fin.
18. All drivers must wear when racing, Fireproof overalls (Proban), gloves, Crash helmet which must have one of the following British Standard Numbers visible to the Scrutineer, BS 2495, 6658, Snell 70,80 & 90, EC22.05, P/J0511884 with visor and or goggles. Neck braces are also advisable. (Lace up neck braces must not be worn).
19. These rules are primarily for drivers safety, it is however impossible to guarantee drivers safety and all racers should realise they race at their own risk. It is recommended that all racers take out their own Personal Accident Insurance to cover them against injury whilst racing.

SECTION SEVEN – CONTACT RACING

STREET BANGERS - Min age 17yrs.

1500cc Front wheel drive / 1600cc Rear wheel drive limit at all meetings. No Vans or Pickups.

Great formula designed to get youngsters on track racing. Contact limited to pushing from behind and spinning cars either way. Following into the Armco, jacking stationary cars etc is not allowed, offenders will be loaded up and banned from Street Bangers. Number of laps will be determined by the entry and the first lap of all races is non-contact.

CAR ELIGIBILITY AND PREPARATION

1. Any 2 wheel drive Saloon, Hatchback or Estate car allowed, carburettor, injection or turbo. Engine, Gearbox and differential must remain standard.
2. All lights, glass, exterior trims, wheel weights and complete tow bars must be removed. Sunroofs must be plated with at least body thickness metal. Front Bumpers must be removed.
3. Dashboard removal is strongly recommended. Ignition switch must be accessible to driver and clearly marked ON/OFF. Steering lock removal is recommended, if retained the ignition key must be secured with a cable tie or wire loop to keep it near the switch.
4. Roll Cage - An H frame must be fitted behind the drivers seat to act as a roll cage and seat support. Minimum 4 bolt fixing to roof and floor to protect the driver in the event of a rollover. All bolts must have good sized washers and be a minimum of 17mm head bolts. All bars in close proximity to driver to be well padded.
5. No armouring whatsoever. Except drivers door where a plate must be fitted, it must be of flat plate, minimum 10mm and maximum 25mm thickness. It must not extend forward of the front pillar more than 6 inches or rear of the back pillar by more than 12 inches. It must be secured with min 4 substantial bolts with large washers. At least 2 Bolts must pass through the pillars.
6. Bonnet / Boot lid must only be tied down. No bolts, No plates. Passenger doors must be tied / taped shut.
7. Seat must be high backed, incorporate a headrest and be securely fastened.

8. A fully approved safety harness (minimum 4 point fixing) to be fitted, bolted to the H frame or to sound floor i.e. Original mounting points or 75mm.x 75mm plates to be fitted under car as washers.
9. Fuel tank must be of stout construction with no more than 3 gallons capacity. No motorcycle tanks. Tank must be fitted into the passenger footwell or incorporated in a proprietary H frame. All tanks must have a sealed filler cap and a breather from top of tank to discharge through car floor. Fuel taps optional but if fitted must be of good quality. Original fuel tanks be removed or punctured.
10. Battery must be covered with rot proof material to avoid spillage, if in a vulnerable position under the bonnet it may be positioned inside the car in a securely fastened battery box, preferably in a box built into a proprietary H frame.
11. Cars must have good working footbrakes at all times.
12. Efficient exhaust systems must be fitted. Cars exceeding 98 decibels may be black-flagged by the clerk of the course.
13. No distributor protection allowed. All bulkhead holes must be sealed.
14. Radiators must remain in original position with breathers directed at the track. No water tanks allowed, anyone found to have fitted a water tank after scrutineering will be loaded up. No Anti freeze.
15. Race Numbers to be displayed on the doors in contrasting colours and on a minimum 6+white roof fin with black numbers.
16. All drivers must wear when racing, Fireproof overalls (Proban), gloves, Crash helmet which must have one of the following British Standard Numbers visible to the Scrutineer, BS 2495, 6658, Snell 70,80 & 90, EC22.05, P/J0511884 with visor and or goggles. Neck braces are also advisable. (Lace up neck braces must not be worn).
17. Maximum wheel size 6J. Alloy wheels must be fitted with the correct Bolts/Nuts. Tubes recommended, gaiters optional. Standard road tyres only, no competition or racing tyres.
18. Everything you bring to the track must be taken away at the end of the day especially punctured wheels; bumpers that fall off **MUST** be recovered and taken away.
19. These rules are primarily for drivers safety, it is however impossible to guarantee drivers safety and all racers should realise they race at their own risk. It is recommended that all racers take out their own Personal Accident Insurance to cover them against injury whilst racing.

F2 STOX - Min age 17yrs.

Any car built to Brisca F2 or Spedeworth Superstox spec allowed.

Exceptions:

1. Tyres free / Wheels up to 10J back, 6J Front.
2. Bumpers - 3mm steel max. 100mm - 150mm deep, 30mm thick. Height: Ground to centreline between 16 ½+ (+/- 1+). Ride over hoops should be fitted. Bolt on bumpers must have secondary chains to contain them.
3. Minimum contact only, nudging into the corners and leaning on cars is allowed. Deliberate ramming and pushing in to the Armco is not allowed with offenders being severely dealt with.

BANGERS - Min age 17yrs.

Banger racing is a full contact sport - These rules are primarily for drivers safety, it is however impossible to guarantee drivers safety and all racers should realise they race at their own risk. It is recommended that all racers take out their own Personal Accident Insurance to cover them against injury whilst racing.

BANGER RULES AND CAR PREPARATION

1. Deliberate driver side contact and central T bones to either side are not allowed. No racing the opposite way. No attacking on or off the centre green. No jacking stationary cars. These are all load up or banable offences.
2. Any Saloon, Hatchback or Estate car allowed, carburettor, injection or turbo. Various cc limits apply at all meeting, please check fixture list for cc limits at each meeting.
3. No Pickups, No station wagon or off road 4 x 4. Car derived 4 x 4 (Sierra etc) are allowed. Large American and Chassis cars can only race in the Over 1800cc / Unlimited class.
4. No Mondeos in Unlimited Bangers
5. Bangers built to National Banger spec allowed.
6. Sensible engine swaps are allowed, but not to enable a large car to race in a lower cc class.
7. Cars to be of metal construction.
8. Unless there is a specific big team event no more than 4 registered racers cars may be painted in team colours at any Standlake meeting.

9. Bangers must start the meeting with an adequate silencer system and make every effort to retain it during the day. Noisy cars may be black flagged and not allowed to race.
10. All glass, screens, exterior and interior trim, mirrors, lights, wheel weights and drawbar ball hitches to be removed. Dashboards to be removed.
11. Sunroofs - all glass must be removed and a sunroof should be covered with a single metal sheet and secured in at least 6 different places. A steel sunroof should have a plate bolted across it to stop it coming off.
12. No seam welding, or armouring whatsoever.
13. Cars with distributors / Cam belts in a vulnerable position may fit a small guard fastened only to the engine. 3mm max thickness.
14. Roll Cage - An H frame must be fitted behind the drivers seat to act as a roll cage and seat support. Minimum 4 bolt fixing to roof and floor to protect the driver in the event of a rollover. All bolts must have good sized washers and be a minimum of 17mm head bolts. All bars in close proximity to driver to be well padded.
15. A flat doorplate 8+ 15+deep, minimum 10mm maximum 25mm thickness must be fitted. It must be securely bolted with not less than 4 bolts & large washers, it must overlap A and B posts. It must not extend forward of the front pillar more than 6 inches or rear of the back pillar by more than 12 inches. 2 fixing Bolts must go through the pillars, Bolt thread inside the car must be kept to a minimum.
16. Doors, bonnet and boot lid to be securely fastened. Doors & boot may be tack welded with no more than 5 x 25mm tacks. Drivers door must be bolted or welded. Other doors may be secured with Max 12+x 12+plates. No more than 4 bonnet bolts protruding not more than 4". No double bonnets or bumper tyres.
17. All water & coolant must be under the bonnet, steam tanks must be no further forward than the front of the engine and not fastened to the engine. The cooling system should be non-pressurised with an overflow pipe leading from the highest point down to the underside of the car. Antifreeze must be drained and replaced with water.
18. Seat to be secure, sound and supported by the roll cage. High back seat and head with restrainer are compulsory.
19. Batteries to be securely fastened and completely covered with rot proof material to avoid spillage.

20. All cars must have good working foot brakes, drivers must not race if brakes fail.
21. Diffs may be locked, tyres may be gaitered.
22. Petrol tanks must be of stout construction, of no more than three gallon capacity, carrying minimum amount for event. No motorcycle fuel tanks. The petrol tank must be securely fastened, as far as is practicable away from driver. Fuel lines must be secure and sound with no leaks. All tanks to have a sealed filler cap with a breather pipe from the top of the tank discharging through the car floor. Original tank must be removed or punctured with a large hole and must not be used or ballasted.
23. Ignition / Kill switch must be clearly marked and must cut the fuel supply.
24. All racers must present a suitable fire extinguisher at scrutineering, the extinguisher must remain accessible in the racers pit area for the duration of the days racing. Extinguishers must be maintained in top class condition.
25. Racers to display their race numbers on the doors and an appropriately sized roof fin, black on white or white on black.
26. Crash Helmet to BS 6658, Snell 70, 80 & 90 EC 22.05 P/J 0511884 standard.
27. Cars to be fitted with proprietary or approved 4 point min safety harness, securely bolted with large washers and plated to sound metal.
28. All drivers must wear overalls and gloves that are in good condition. It is compulsory you use Flame retardant Proban or higher specification material overalls. Neck braces and the use of flame-retardant balaclavas is highly recommended. Lace up neck braces must not be worn. Wet weather clothing must be worn as well as, not instead of overalls.
29. Cars may be re scrutineered at any time during the meeting, if it is felt they are unsafe they will not be allowed to race.
30. In the interest of the safety of the driver, racers presenting their cars for scrutineering and failing to comply with these rules may not be allowed to race.
31. **ALL WHEELS & TYRES & RUBBISH MUST BE TAKEN HOME.** Cars may be left for scrap subject to the appropriate charge being paid / collected and cleared with Keith.
32. Scrutineers and Promotion's decisions are FINAL.

SEGTO TRACKS 2010

STANDLAKE ARENA . prefix X

Web Site www.standlakearena.co.uk
Contact Keith Hook - 01993 200964 / 07720372842
 Carolyn Simmonds - 01993 851215
Email contactkeith@ntlworld.com

Southern Autosport Association (SAA) . prefix S

Web Site www.saaraceway.co.uk
Contact Tony Mellish 01243 375286
 Rob Dance 07765830997
Email damellish@btinternet.com

Tongham Motor Club (TMC) . prefix T

Web Site www.tonghammotorclub.co.uk
Contact Mandy Sherwood 01256 842210
 Rudge Stockham 07921769582
Email mandy.sherwood@btinternet.com

SEGTO OFFICIALS

Chairman Tony Mellish 01243 375286 / 07796016772
Secretary Sue Mellish 01243 375286 / 07599915908
Treasurer Stuart Weaver 01732365083
Technical C/man Andy West 07834859885
Competition Sec Emma Connors 01932 827153 / 07775608763